

Thermal Analysis Excellence



DSC 3

STAR[®] System

Innovative Technology

Versatile Modularity

Swiss Quality



Differential Scanning Calorimetry for Routine Analysis

METTLER TOLEDO

Unmatched DSC Performance Tailored Exactly to Your Needs

Differential scanning calorimetry (DSC) is the most frequently used thermal analysis technique. DSC measures enthalpy changes in samples due to changes in their physical and chemical properties as a function of temperature or time.

Features and benefits of the METTLER TOLEDO DSC 3:

- **Rugged MultiSTAR^e sensor with 56 thermocouples** – detects the smallest and largest thermal effects
- **Robust endurance-tested sample robot** – operates efficiently and reliably around the clock
- **Start the experiment with just One Click™** – fast and easy routine operation
- **Simple FlexCal[®] calibration** – saves time and results in precise and accurate measurements
- **Modular concept protects your investment** – fulfills your current and future needs
- **Wide temperature range** – from –150 to 700 °C in one measurement
- **Intelligent ergonomic design** – simplifies instrument operation
- **Comprehensive services** – professional support for your daily work

The DSC uses a robust and versatile DSC sensor with 56 thermocouples which guarantees simultaneous outstanding resolution and sensitivity.



Major Breakthrough in DSC Sensor Technology

Unsurpassed Sensitivity and Excellent Resolution

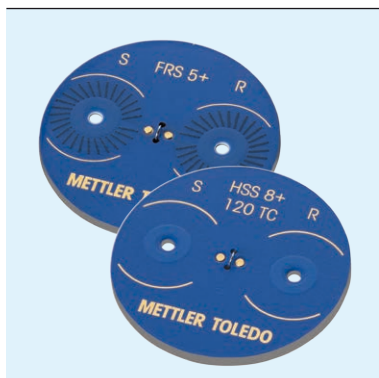

Don't make any compromises concerning the sensor, the heart of your DSC. The **METTLER TOLEDO MultiSTAR®** sensors successfully combine a number of important characteristics that are unattainable with conventional sensors and that until now have been impossible to achieve. These included high sensitivity, excellent temperature resolution, a perfectly flat baseline and robustness.

Temperature resolution

The signal time constant determines how well close-lying or overlapping thermal effects are separated from one another. We set unprecedented and unparalleled performance standards due to our high thermal conductivity ceramic sensor material with its low thermal mass.

Baseline

Our revolutionary star-shaped arrangement of thermocouples around the sample and reference crucibles completely compensates any possible temperature gradients. This guarantees flat baselines and reproducible measurement results.

FRS 5+ sensor

The Full Range FRS 5+ sensor has 56 thermocouples and provides high sensitivity and unprecedented temperature resolution. Thanks to its ceramic surface it is robust and chemically resistant making it ideal for daily use.



One Click™ function

The patented One Click™ function allows you to start predefined methods safely and easily from the terminal at the touch of a button.

DSC 3 from METTLER TOLEDO

the Right Decision

SmartSens terminal with One Click™ function

The terminal with the One Click™ function is clearly visible even at a distance and provides information on the status of the measurement. The One Click™ function allows you to easily and efficiently start a predefined method.

If the DSC is not installed next to a PC running the STAR® software, you can set up individual sequences directly at the instrument terminal. The adaptable and intuitive touchscreen or SmartSens allows you to switch screens or open the furnace handsfree.



Furnace chamber

The sensor is located in a corrosion-free silver furnace.

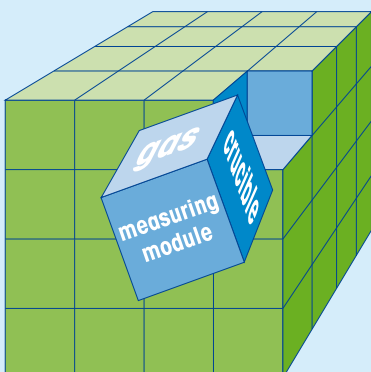
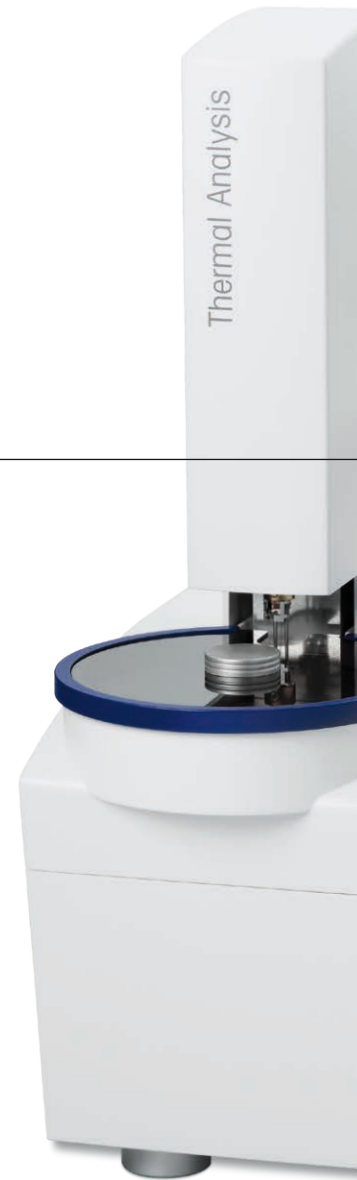

FlexCal® adjustment

The STAR® software stores a complete adjustment data record in the database for every crucible, gas and module combination. The module always uses the correct adjustment parameters, even if measurements are performed with different crucibles or if the gas is switched during the measurement.

Ergonomics in Perfection

We Care about You

Ergonomic design

If you insert samples manually, you can rest your hand on an ergonomically shaped support surface.



DSC



TGA



TMA



DMA

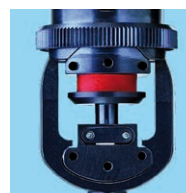

Complete thermal analysis system

A complete thermal analysis system comprises four different techniques. Each technique characterizes the sample in a particular way.

The combination of all the results simplifies interpretation. DSC measures the heat flow, TGA the weight curve, TMA the length change, and DMA the modulus.

The powerful STAR[®] software allows the user to control all the connected modules and provides unlimited evaluation possibilities.

Support and repair

Support and diagnosis in case of technical issues. Carrying out repairs at a customer's site or at one of our service centers.



Quality assurance and certification

Qualification, documentation, calibration with certificate.



Performance services and preventive maintenance

Professional installation (IQ, OQ) and ensuring optimum performance during the life-time of the instrument (PQ and preventive maintenance).

Training and applications support

Professional applications support, basic and customized training courses, comprehensive applications literature.

Unsurpassed Performance over the Whole Temperature Range

Measurement principles

Differential scanning calorimetry (DSC) measures the difference between the heat flows from the sample and reference sides of a sensor as a function of temperature or time.

Physics of DSC

Differences in heat flow arise when a sample absorbs or releases heat due to thermal effects such as melting, crystallization, chemical reactions, polymorphic transitions, vaporization and many other processes. Specific heat capacities and changes in heat capacity, for example during a glass transition, can also be determined from the difference in heat flow.

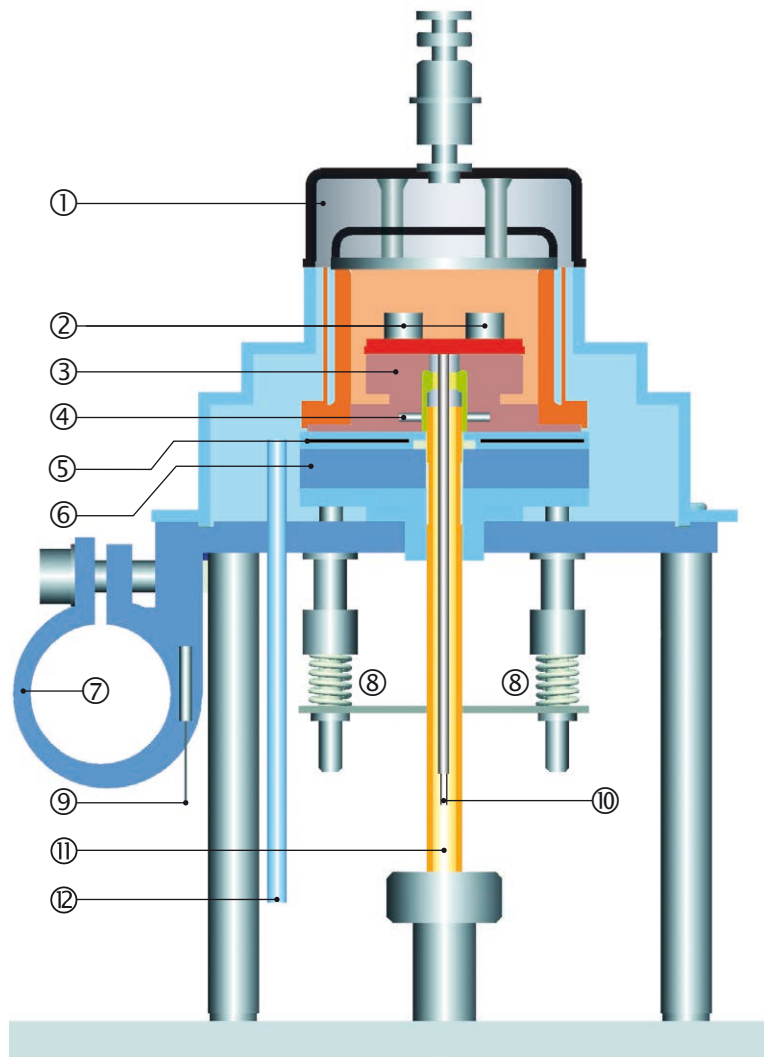

TAWN test

The benchmark for DSC sensors is the widely used TAWN test. The test confirms the excellent sensitivity and high temperature resolution of the HSS 8+ and FRS 5+ sensors.

Key

- | | |
|---|------------------------------------|
| 1. Furnace lid | 6. Thermal resistance for cooler |
| 2. Crucibles on the DSC sensor | 7. Cooling flange |
| 3. Silver furnace | 8. Compression spring construction |
| 4. PT100 of furnace | 9. Cooling flange PT100 |
| 5. Flat heater between two insulating disks | 10. DSC raw signal for amplifier |
| | 11. Purge gas inlet |
| | 12. Dry gas inlet |

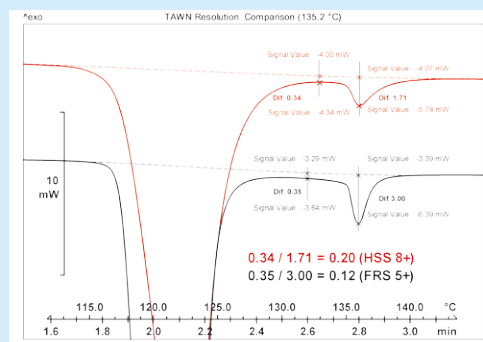
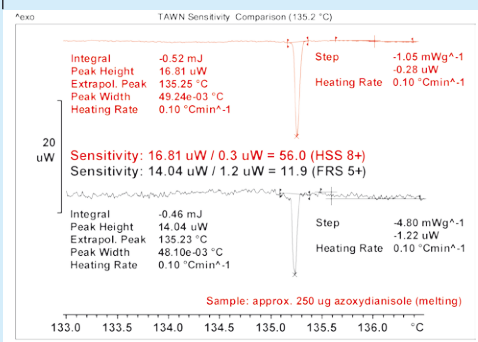

Reliable Automation Saves Time

The sample robot is extremely robust and operates reliably 24 hours a day throughout the whole year.

Automatic and efficient

All DSC models can be automated. The sample robot can process up to 34 samples even if every sample requires a different method and a different crucible.



Features and benefits:

- **Up to 34 sample positions** – dramatically increases efficiency
- **Simple and rugged design** – guarantees reliable results
- **Unique “wasp” lid piercing accessory** – hermetically sealed crucibles are automatically opened prior to measurement
- **Universal gripper** – can handle all types of METTLER TOLEDO crucibles



No sample reaction before measurement

The sample robot can remove the protective crucible lid from the crucible or can pierce the lid of hermetically sealed aluminum crucibles immediately before measurement. This unique feature prevents the sample from taking up or losing moisture between weighing-in and measurement. It also protects oxygen-sensitive samples from oxidation.

Modularity and Upgradeability

Unlimited Possibilities

Automatic furnace lid

The automatic furnace lid opens and closes the furnace chamber at a keystroke or when actuated by the SmartSens infrared sensors. Manual removal and replacement of the furnace lid is no longer necessary. The measurement cell is effectively isolated from the environment thanks to its optimized design with three superimposed silver lids and its heat shield.



Air cooling	RT to 500 °C / 700 °C
Cryostat cooling	-50 to 450 °C / 700 °C
IntraCoolers (several)	-35 to 450 °C / 700 °C -85 to 450 °C / 700 °C -100 to 450 °C / 550 °C
Liquid nitrogen cooling	-150 to 500 °C / 700 °C

Temperature range and cooling options

You can adapt the system to your requirements depending on the temperature range in which you want to measure.

The IntraCooler is a sealed system requiring only electrical power. It is therefore advantageous in locations where liquid nitrogen is undesirable or not available. Liquid nitrogen cooling offers greater flexibility because it allows you to measure over the entire temperature range.

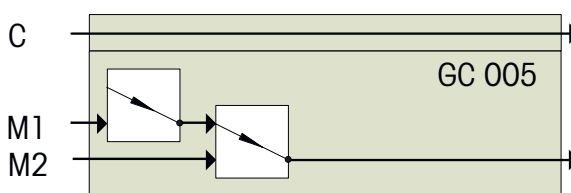

Defined furnace atmosphere, programmable gas flow and gas switching

The furnace chamber can be purged with a defined gas. This process is software controlled, which makes it very easy to switch from an inert atmosphere to reactive conditions.

Option → required option	FRS 5+	HSS 8+	Automatic furnace lid	SmartSens terminal	Peripheral control	Switched line socket	GC 302 / GC 402	Air cooling	Cryostat	Intra-Cooler	Liquid nitrogen
DSC 3 (500 °C)	•	•	optional	optional				•	•	•	•
DSC 3 (700 °C)	•	•	optional	optional				•	•	•	•
Sample changer (34)			essential	essential							
Automatic furnace lid				essential							
Gas controller (GC 302)				recommended			optional				
Gas flow-switch (GC 005)				optional			optional				
Cryostat / Intra-cooler						optional (recommended)					
Liquid nitrogen cooling					essential						

• = selectable

Innovative Accessories

Increase Measurement Power

DSC microscopy

DSC curves often exhibit effects that cannot immediately be explained. In such cases, it is often helpful to visualize the changes in the sample directly by means of microscopy.

The versatile optical accessory can be used with any METTLER TOLEDO DSC. It consists of an optical system, a CCD camera, and image capture and processing software.



DSC photocalorimetry

The photocalorimetry accessory for the DSC allows you to characterize UV curing systems. You can study photo-induced curing reactions and measure the effects of exposure time, UV light intensity and temperature on material properties.



Crucible sealing press

Enormous range of crucibles

We have the right crucible for every application. The crucibles are made of different materials with volumes ranging from 20 to 900 μL and for high pressures. All the different types can be used with the sample robot.

Crucible materials available include:

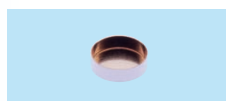

copper

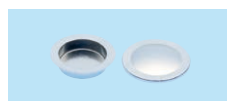

aluminum

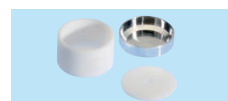

alumina



steel (gold-plated)

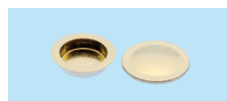

gold



platinum

Extremely Wide Application Range

Differential Scanning Calorimetry measures the enthalpies associated with transitions and reactions and the temperatures at which these processes occur. The method is used for the identification and characterization of materials.

Differential scanning calorimetry (DSC) is fast and very sensitive. Sample preparation is easy and requires only small amounts of material. The technique is ideal for quality control, material development and material research.

DSC is the method of choice to determine thermal quantities, study thermal processes, and characterize or just simply compare materials. It yields valuable information relating to processing and application conditions, quality defects, identification, stability, reactivity, chemical safety and the purity of materials.

The method is used to analyze and study materials such as thermo-plastics, thermosets, elastomers,

composite materials, adhesives, foodstuffs, pharmaceuticals and chemicals.

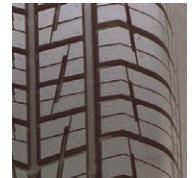
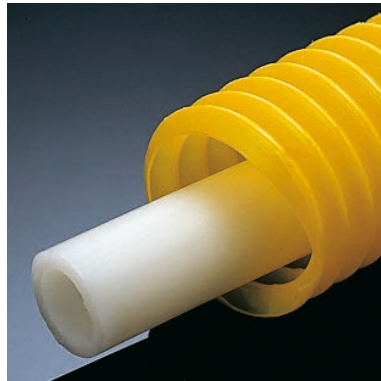
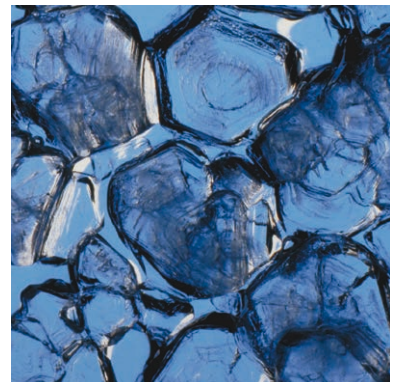
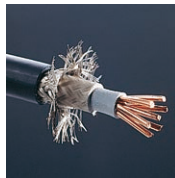

Examples of thermal events and processes that can be determined by DSC

- Melting behavior
- Crystallization and nucleation
- Polymorphism
- Liquid-crystalline transitions
- Phase diagrams and composition
- Glass transitions
- Reactivity
- Reaction kinetics
- Curing
- Stability
- Miscibility
- Effects of plasticizers
- Thermal history
- Heat capacity and heat capacity changes
- Reaction and transition enthalpies
- Purity

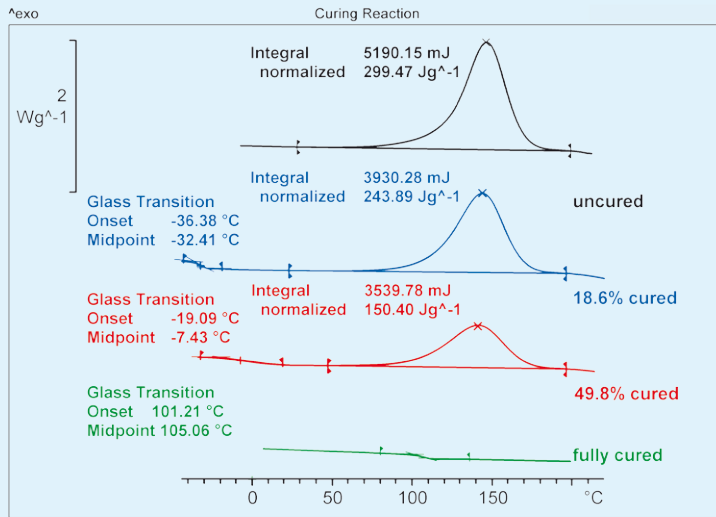

Epoxy systems

An important application of DSC is to measure the glass transition and the curing reaction in epoxy resin systems. The figure displays the curing curves of samples previously cured to different extents. The results show that as the degree of cure increases the glass transition shifts to higher temperatures and the postcuring reaction enthalpy decreases. If the reaction enthalpy of the uncured material is known (in this example, 299.5 J/g), the degree of conversion can be calculated from the enthalpy of the postcuring reaction.

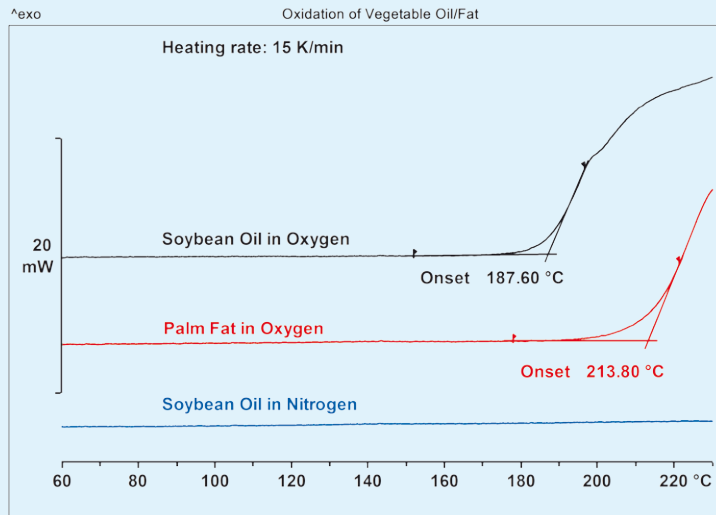

Oxidation of vegetable oils

Oxidation causes rancidity in edible oils and fats, giving them an unpleasant odor and taste and making them unsuitable for cooking. By determining the Oxidation Onset Temperature (OOT) the thermal stability can be measured and used oils can be distinguished from fresh oils. The diagram shows the OOT curves of soybean oil and palm fat. In each case, about 2 mg of the oil or fat was weighed into 40- μ L standard aluminum crucibles. The soybean oil shows that oxidation begins at about 188 °C under oxygen but shows no visible signs of reaction under nitrogen. Similarly, palm fat begins to oxidize at about 213 °C.

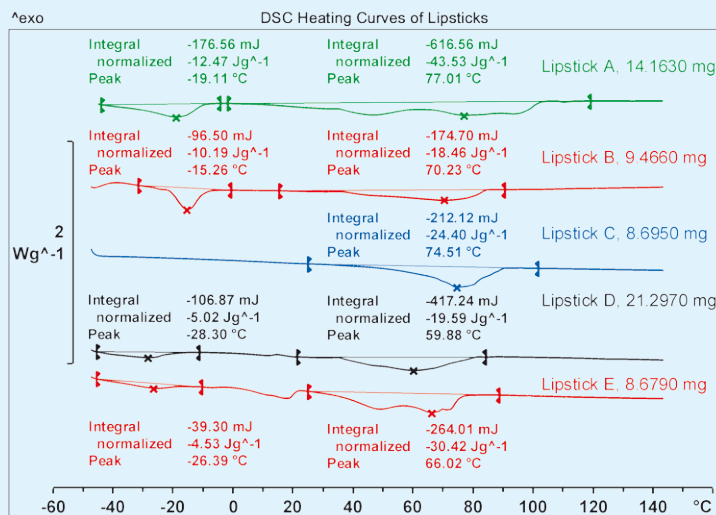
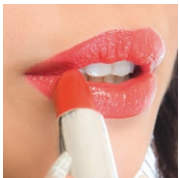

Identification of lipsticks

Lipsticks contain waxes, oils, pigments, and emollients commonly known as moisturizers. The diagram shows heating curves of five different lipsticks labeled Lipstick A, B, C, D, and E. Measurements like this are typically performed at heating rates of 5 or 10 K/min. The waxes and oils are initially solid but melt on heating, giving rise to endothermic peaks. DSC analysis can be used to obtain melting profiles and to characterize and distinguish between different lipsticks. The results also provide information about the practical performance of lipsticks. For example, the lower-melting lipstick D should spread well, a higher-melting lipstick like C wear well.

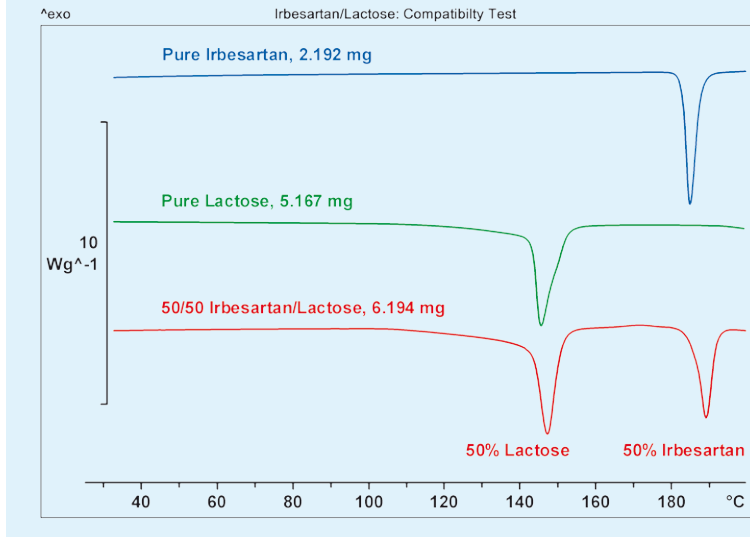

Compatibility in a formulation

DSC is an important method in preformulation studies to quickly obtain information about interactions between different constituents of a formulation. Pure irbesartan exhibits a melting peak at about 185 °C and pure lactose monohydrate a peak at about 146 °C which is related to the evaporation of water. It can be seen that the melting peak of irbesartan in a 50/50 mixture shows no significant change or shift due to the presence of lactose. This indicates that irbesartan is compatible with lactose monohydrate.

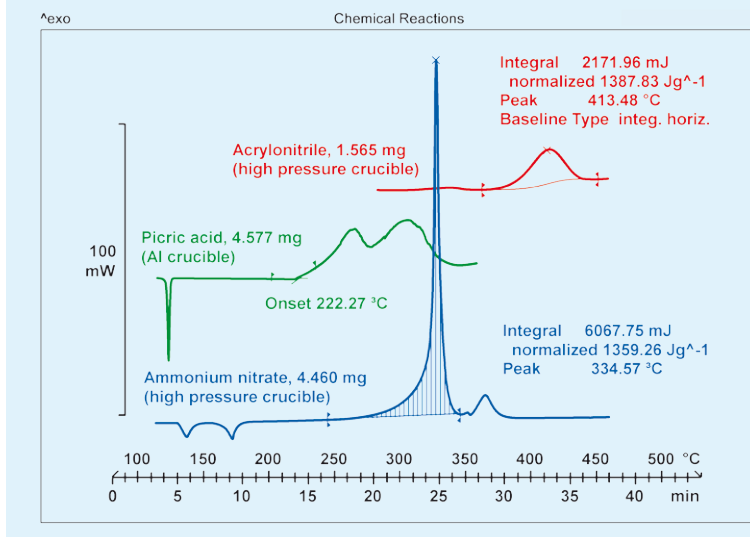

Chemical reactions

The question of reactivity plays a central role in assessing the stability of chemicals. It is important to know the reaction rate and the energy released in a reaction at a particular temperature. Information about the decomposition reaction that can be obtained from DSC curves is very useful for safety studies, for example with autocatalytic reactions.

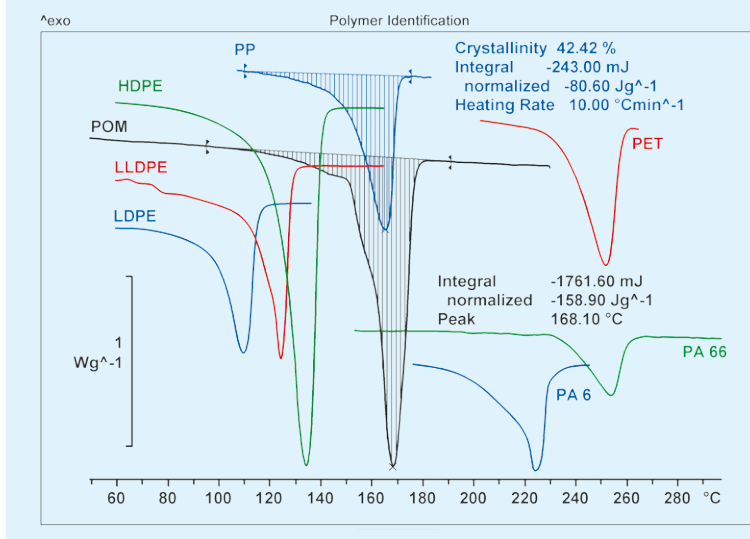

Identification of plastics

Plastics can be identified by measuring their glass transition temperatures and melting temperatures. The figure shows the melting peaks of different polymers. The peaks clearly differ in size and their position on the temperature axis. The example of PP and POM shows that identification depends both on the melting point and on the enthalpy of fusion. If the type of polymer is known, the degree of crystallinity can be determined from the melting peak.

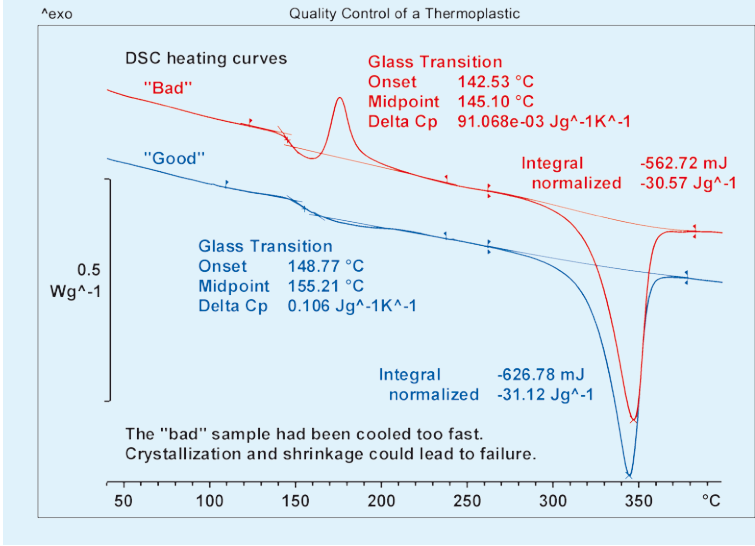
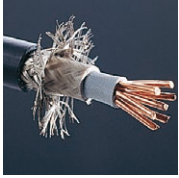

Failure analysis of a thermoplastic

The diagram shows DSC heating curves of two semicrystalline thermoplastic seals. The "Bad" seal failed when the temperature reached about 150 °C. This material exhibited a glass transition at about 145 °C immediately followed by a crystallization process. In contrast, the "Good" material showed just the glass transition at about 155 °C. During crystallization, the material shrinks. This is the reason why the "Bad" seal failed. The different behavior shown by the two seals is due to differences in the processing conditions – the bad seal had been cooled too quickly. As a result of this, the material did not have enough time to crystallize completely.

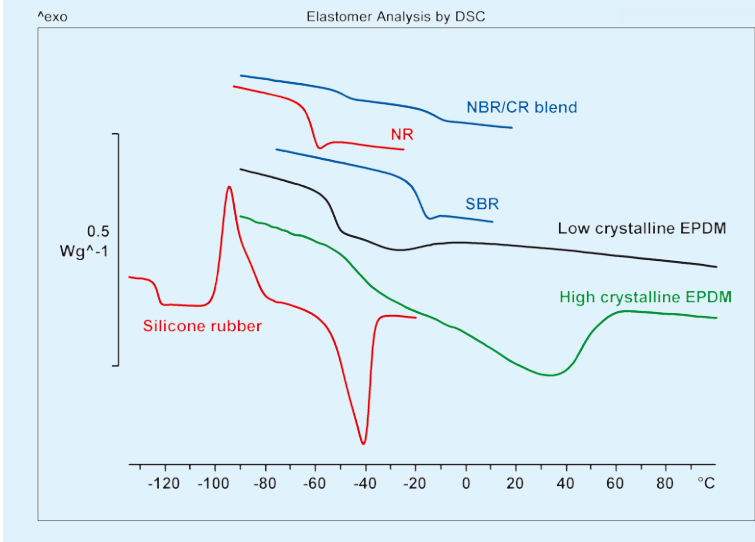

Elastomer analysis

DSC can be used to identify elastomers. The method makes use of the fact that glass transitions and melting and crystallization processes occur below room temperature. These are specific for a particular elastomer. In elastomer analysis, DSC is an important complementary technique to thermogravimetric analysis (TGA).

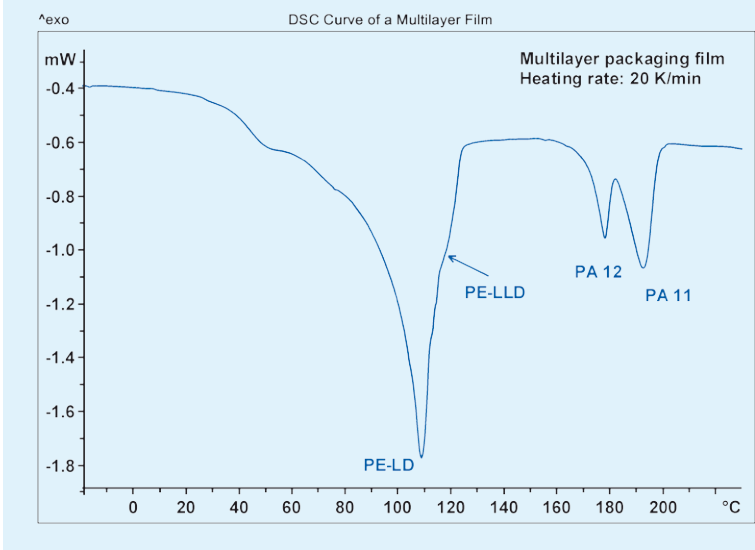
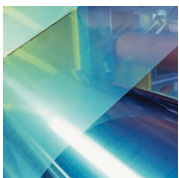

Identification of film layers

Flexible food and pharma packaging films are often made of several layers of thin thermoplastic polymer films. This ensures good mechanical and barrier properties. In this example, four different polymers were identified by comparing peak temperatures with reference values. The broad peak with peak temperature at about 108 °C is due to the melting of low-density polyethylene (PE-LD). The shoulder at about 120 °C can be assigned to the melting of linear low-density polyethylene (PE-LLD). The peaks at 177 and 191 °C result from the melting of polyamide 12 (PA 12) and 11 (PA 11), respectively. The small step at 40 °C is due to the glass transition of the polyamide.

DSC 3 Specifications

Temperature data

Temperature range	air cooling	RT to 500 °C (200 W)	RT to 700 °C (400 W)
	cryostat cooling	-50 to 450 °C	-50 to 700 °C
	IntraCooler	-100 to 450 °C	-100 to 700 °C
	liquid nitrogen cooling	-150 to 500 °C	-150 to 700 °C
Temperature accuracy ¹⁾		± 0.2 K	
Temperature precision ¹⁾		± 0.02 K	
Furnace temperature resolution		± 0.00006 K	
Heating rate ²⁾ RT to 700 °C		0.02 to 300 K/min	
Cooling rate ²⁾		0.02 to 50 K/min	
Cooling time	air cooling	8 min (500 to 100 °C)	9 min (700 to 100 °C)
	cryostat cooling	5 min (100 to 0 °C)	
	IntraCooler	5 min (100 to 0 °C)	
	liquid nitrogen cooling	15 min (100 to -100 °C)	

Calorimetric data

Sensor type	FRS 5+	HSS 8+	
Sensor material	Ceramic		
Number of thermocouples	56	120	
Signal time constant	1.8 s	3.1 s	
Indium peak (height to width)	17	6.9	
TAWN	resolution	0.12	0.20
	sensitivity	11.9	56.0
Measurement range	at 100 °C	± 350 mW	± 160 mW
	at 700 °C	± 200 mW	± 140 mW
Resolution	0.04 µW	0.02 µW	
Digital resolution	16.8 million points		

Sampling

Sampling rate	maximum 50 values/second
---------------	--------------------------

Special modes

ADSC	standard
IsoStep®	optional
TOPEM®	
Automation	
Photocalorimetry	

Approvals

IEC/EN61010-1:2001, IEC/EN61010-2-010:2003
 CAN/CSA C22.2 No. 61010-1-04
 UL Std No. 61010A-1
 EN61326-1:2006 (class B)
 EN61326-1:2006 (Industrial environments)
 FCC, Part 15, class A
 AS/NZS CISPR 22, AS/NZS 61000.4.3
 Conformity mark: CE

¹⁾ based on metal standards

²⁾ depends on instrument configuration

www.mt.com/DSC

For more information

Mettler-Toledo AG, Analytical

CH-8603 Schwerzenbach, Switzerland
 Tel. +41 44 806 77 11
 Fax +41 44 806 72 60

Subject to technical changes

© 05/2015 Mettler-Toledo AG, 30247073A
 Marketing MatChar / MarCom Analytical



Quality certificate. Development, production and testing according to ISO 9001.



Environmental management system according to ISO 14001.



"European conformity" The CE conformity mark provides you with the assurance that our products comply with the EU directives.