

Thermal Analysis Premium



**TMA/SDTA 2+
STAR[®] System**

Innovative Technology

Versatile Modularity

Swiss Quality



Thermomechanical Analysis for All Requirements

METTLER TOLEDO

Outstanding Measurement Performance Thanks to Swiss Precision Mechanics

Thermomechanical analysis (TMA) is used to measure dimensional changes of a material as a function of temperature. Thermal expansion and effects such as softening, crystallization and solid-solid transitions determine the potential applications of a material and provide important information about its composition. Viscoelastic behavior can be studied by varying the applied force (DLTMA mode).

Features and benefits of the METTLER TOLEDO TMA/SDTA 2+:

- **Wide temperature range** – from –150 to 1600 °C
- **SDTA** – for the simultaneous measurement of thermal effects
- **One Click™** – provides efficient sample measurement
- **Nanometer resolution** – allows very small dimensional changes to be measured
- **Dynamic load TMA (DLTMA mode)** – measures weak transitions and elasticity
- **Wide measurement range** – for small and large samples
- **Modular design** – allows future expansion to meet new requirements
- **Hyphenated techniques** – for Evolved Gas Analysis using MS, GC-MS, or FTIR

The TMA/SDTA 2+ incorporates Swiss precision mechanics and is available in four versions with furnace systems optimized for measurements between –150 and 1600 °C.



SDTA Signal

Unsurpassed Temperature Accuracy



The TMA/SDTA 2+ is the only instrument on the market that measures the sample temperature very close to the sample in all operating modes. This enables temperature adjustment to be carried out using reference substances (e.g. the melting points of pure metals) or through a change in length.

The SDTA signal is the difference between the measured sample temperature and the reference temperature calculated using a model (US Patent 6146013). This means that besides the length change, the simultaneously measured SDTA signal is also available as a measurement quantity. In many cases, this can facilitate the correct interpretation of a measurement curve.

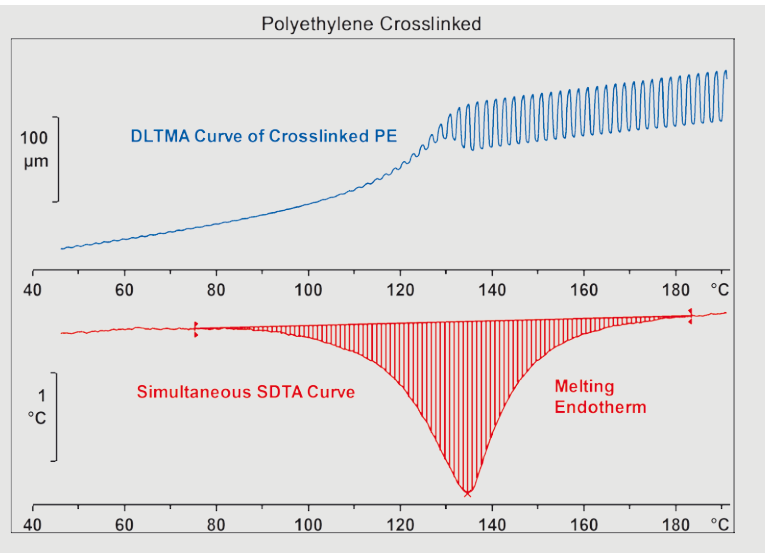

DLTMA mode

The DLTMA mode allows you to study the elastic behavior of samples.

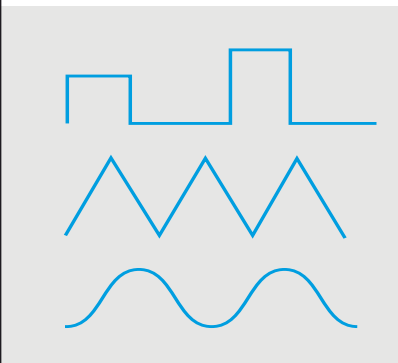

Unique temperature calibration

The METTLER TOLEDO TMA models have two thermocouples: One measures the furnace temperature and controls the program temperature. The other is located next to the sample and measures the sample temperature.

Rapid Results

Thanks to Innovative Solutions

Easy sample installation

The sampling area is freely accessible for installing the sample holder and measuring probe. These operations can be performed quickly and easily. An indentation ensures that the sample holder can only be installed in one position.

The measuring probe is securely attached to the length sensor (LVDT) by means of a magnet and can easily be changed.

Different sample holders and measuring probes are available for each measuring mode. This allows you to choose the best configuration for each application.



Complete thermal analysis system

A complete thermal analysis system consists of four different measurement techniques. Each characterizes the sample in its own specific way. The combination of all the results gives the complete picture and simplifies interpretation. DMA measures the mechanical modulus, DSC and Flash DSC the heat flow, TGA the weight curve, and TMA the length change. All these quantities change as a function of temperature.

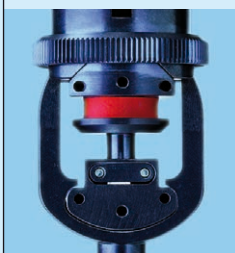

DMA



DSC

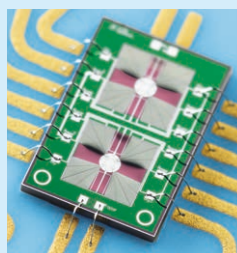

Flash DSC



TGA



TMA

Sophisticated Solutions Down to the Last Detail

Touchscreen terminal for the TMA/SDTA 2+ – with One Click™ technology

The touch-sensitive color terminal for the TMA/SDTA 2+ presents clear and precise information and is easily seen from a distance.

- The patented One Click™ function allows you to start predefined measuring methods safely and easily from the terminal at the touch of a button.
- All force and length calibration routines are controlled via the terminal. This ensures that calibrations are performed reliably and easily.
- The touch screen can be used to control the determination of sample length and the transfer of data to the software. This eliminates any possible transfer errors.



SmartSens functions

In some applications, for example high-precision length measurements, the measuring probe must exert only a very low force on the sample. This means that the instrument should not be touched during the measurement. Basic operations such as opening and closing the furnace and the selection of measurement parameters can therefore be performed in hands-free operation using hand movements.



Matching accessories

So that you can quickly find everything you need, we supply a high-quality wooden storage case for your high-precision, quartz glass and aluminum oxide sample holders and probes, and any other tools and accessories you may have. The foam insert provides each part with its own defined place, offering ideal protection from potential damage.

Reliable, First-Class Performance Over the Entire Temperature Range

Measurement principle

Thermomechanical analysis measures the change in length of a sample as a function of temperature and the applied force.

Wide measurement range

16 000 000 data points are available for the entire measurement range of ± 5 mm. This means that both small and large samples (maximum 20 mm) can be measured with 0.5 nm resolution without the need for range switching.

Thermostating

The mechanical part of the measuring cell is accommodated in a thermostated housing. This guarantees excellent accuracy for the determination of expansion coefficients. Water from the circulator is also used to cool the furnace and reduce cooling times.

Defined furnace atmosphere

The furnace chamber can be purged with a defined gas. This process is software controlled, which makes it very easy to switch from an inert atmosphere to reactive conditions.

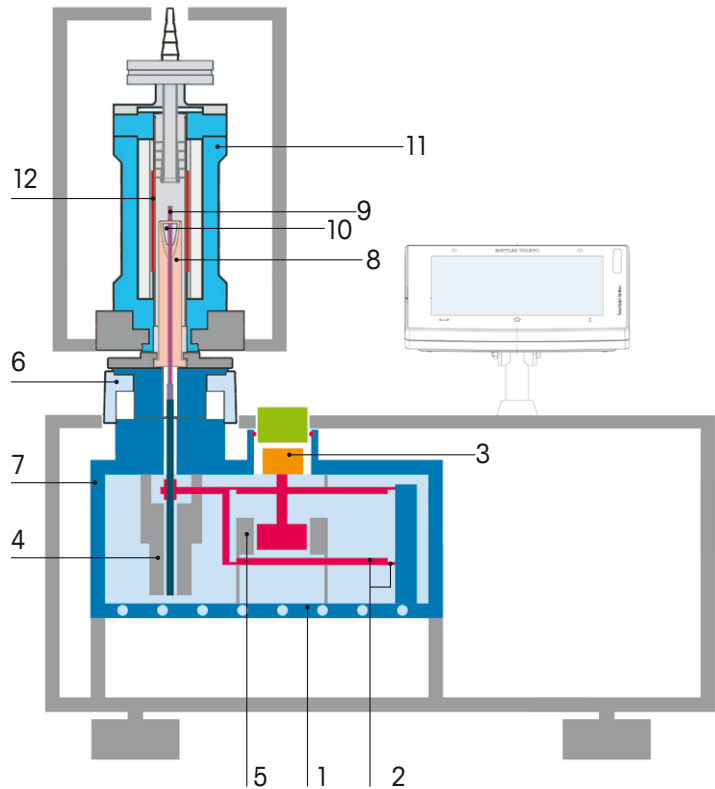

Key

- | | |
|---|--------------------------------|
| 1 Water cooling | 7 Thermostated measuring cell |
| 2 Parallel guidance with bending bearings | 8 Sample support |
| 3 Adjustment weight | 9 Measuring probe |
| 4 Transducer (LVDT) | 10 Sample temperature sensor |
| 5 Force generator | 11 Water-cooled furnace jacket |
| 6 Height adjustment | 12 Furnace heating |

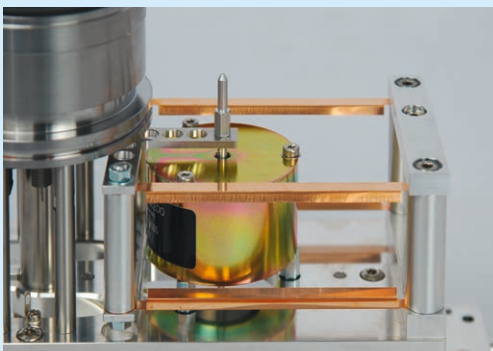

Parallel guidance of the mechanical system

A key feature of the TMA cell is the parallel guidance system of the measuring probe. This utilizes an extremely precise mechanical system based on internationally acclaimed METTLER TOLEDO balance technology. Thanks to this development, the measuring probe can move up and down perfectly free from any frictional forces. The force applied is therefore extremely accurate.

Optimized Sample Holders for Quick and Easy Handling

The TMA/SDTA 2+ offers various accessories that enable you to measure samples in different deformation modes. The most suitable mode for your particular application depends on the nature and properties of the particular sample.

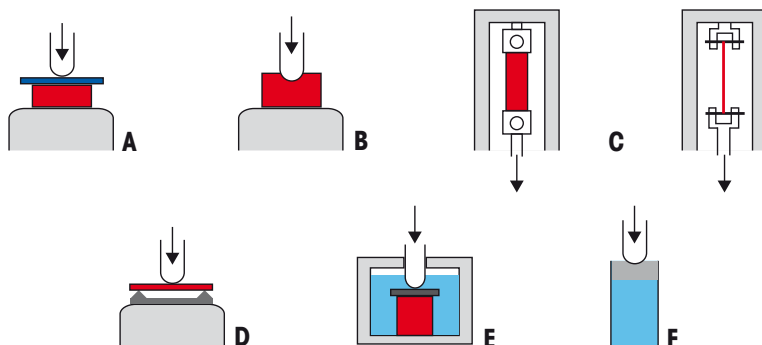

The various deformation modes

Dilatometric mode (A): This is the mode most commonly used in thermomechanical analysis. The expansion coefficient is determined as a function of temperature. A typical feature of this mode is that the probe exerts only a very small force on the sample.

Compression mode (A): In this mode, the sample is subjected to a large force.

Penetration mode (B): The purpose of a measurement in the penetration mode is to determine the softening point of a sample. This is usually performed using the ball-point probe.

Tension mode (C): The fiber or film accessory is used to perform measurements in tension. This allows you to determine changes in length due to shrinkage or expansion.

3-point bending mode (D): This mode is ideal for studying the elasticity of stiff samples such as fiber-reinforced polymers.

Swelling (E): Many substances swell when they come into contact with liquids. The resulting change in volume or length can be measured using the swelling accessory.

Volume expansion (F): Liquids expand just like solids. A new accessory enables you to measure volume changes of liquids.



High-precision quartz glass measuring probes and sample holders

Swiss quality is also clearly present in the measuring probes and sample holders. We supply the following types of quartz glass probes and sample holders:

- Sample holder for the measurement range 0 to 10 mm
- Sample holder for the measurement range 10 to 20 mm

Unparalleled versatility

Optimum Measurement Configurations

The four TMA/SDTA 2+ versions

The TMA/SDTA 2+ is available in four versions:

- A high-temperature version for measurements from room temperature to 1600 °C.
- A standard temperature version for measurements from room temperature to 1100 °C.
- An IntraCooler version that operates from –80 to 600 °C. The IntraCooler is the most effective cooling option on the market that operates without the use of liquid nitrogen.
- A liquid nitrogen cooling option for the low temperature range from –150 to 600 °C.

Conversion from one TMA version to another is always possible as a service option.



IC/600



LN/600



LF/1100



HT/1600

TMA/SDTA 2+ instrument configuration

Cooling device	IC/600	LN/600	LF/1100	HT/1600
Cooling circulator – cooling capacity >600 W				•
Cooling circulator – cooling capacity >400 W			•	
Cooling circulator – cooling capacity >100 W	•	•		

- Film accessory
- Fiber accessory
- 3-point bending accessory
- Accessories for swelling or volume expansion measurements
- Measuring probes with ball point ends (3.0 mm)
- Measuring probes with flat ends (1.1 and 3.0 mm)
- Measuring probes with knife-edges

The sample holder for the measurement range 0 to 10 mm with the ball-point measuring probe is also available in aluminum oxide for the high-temperature range.

Modular Design

Future Expansion at Any Time

Types of sample holder	TMA/SDTA 2+ configurations			
	IC/600	LN/600	LF/1100	HT/1600
0 to 10 mm sample holder, quartz glass	K-type / included with standard equipment		R-type / included with standard equipment	R-type / optional
10 to 20 mm sample holder, quartz glass	K-type / optional		R-type / optional	
Fiber attachment accessory - set with 1 hook, quartz glass	K-type / optional		R-type / optional	
Film attachment accessory- set with 2 hooks, quartz glass	K-type / optional		R-type / optional	
0 to 10 mm sample holder, aluminum oxide	-		optional	R-type / included with standard equipment

Measuring probes	IC/600	LN/600	LF/1100	HT/1600
	Measuring probe, ball-point, 3 mm, quartz glass	included with standard equipment		
Measuring probe, ball-point, 3 mm, aluminum oxide	-		optional	included
Measuring probe, flat, 3 mm, quartz glass	optional (can be used up to 1100 °C)			
Measuring probe, flat, 1.1 mm, quartz glass	optional (can be used up to 1100 °C)			
Measuring probe, knife-edge	optional (can be used up to 1100 °C)			
3-point bending accessory	optional (can be used up to 1100 °C)			
Swelling accessory	optional (can be used up to 1100 °C)			
Volume expansion accessory	optional (can be used up to 1100 °C)			

Analysis of decomposition products by EGA (Evolved Gas Analysis)

The TMA measurement cell can be coupled to a mass spectrometer or an FTIR spectrometer. The additional information obtained allows better interpretation of the measurement curve.

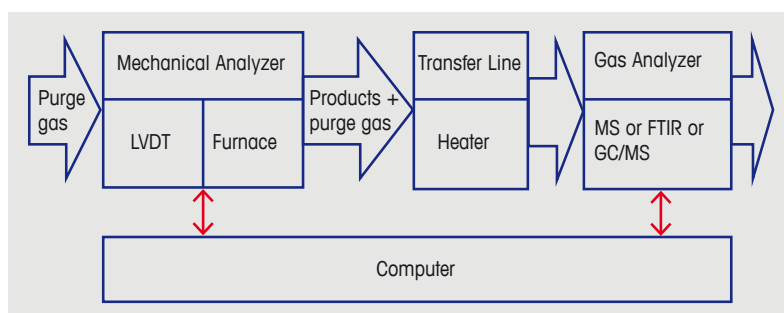

Support and repair

Support and diagnosis in case of technical issues. Carrying out repairs at a customer's site or at one of our service centers.



Quality assurance and certification

Qualification, documentation, calibration with certificate.



Performance services and preventive maintenance

Professional installation (IQ, OQ) and ensuring optimum performance during the life-time of the instrument (PQ and preventive maintenance).

Training and applications support

Professional applications support, basic and customized training courses, comprehensive applications literature.

Thermomechanical Analysis for a Wide Range of Applications

The TMA/SDTA 2+ can be used for a wide range of applications due to its broad temperature range and the wide choice of force parameters in compression and tension modes. As a result, the TMA/SDTA 2+ quickly provides characteristic information on numerous types of samples, for example very thin layers, large sample cylinders, fine fibers, films, plates, soft or hard polymers, and single crystals.

Complementary technique

TMA is the ideal addition to DSC. Besides the measurement of expansion coefficients, TMA is also an excellent technique for determining glass transitions that cannot

be satisfactorily measured by DSC, for example materials with a high filler content. The penetration mode is ideal for characterizing the glass transitions of difficult samples such as very thin coatings.

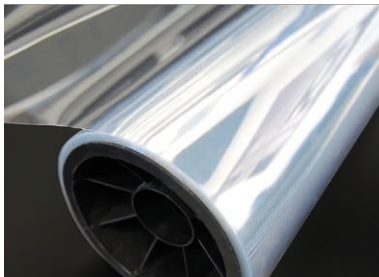
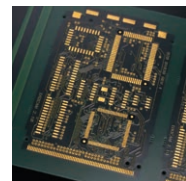

Effects and properties that can be studied using the TMA/SDTA 2+:

- Viscoelastic behavior (Young's modulus)
- Glass transition
- Expansion coefficient
- Expansion and shrinkage of fibers and films
- Softening
- Viscous flow
- Melting and crystallization
- Gelation
- Phase transitions
- Curing and crosslinking reaction
- Swelling behavior
- Volume expansion
- Thermal effects of pharmaceuticals and foodstuffs

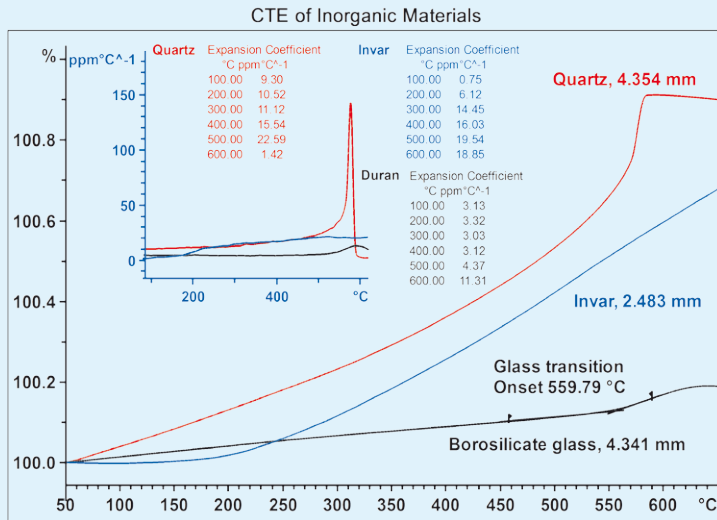

CTE determination

The coefficient of thermal expansion (CTE) can be determined from TMA measurements in the DLTMA mode. The diagram shows dilatometric curves and the resulting expansion coefficients of three different materials. Borosilicate glass has a CTE of about 3.3 ppm in the glassy state and a glass transition at about 550 °C. Invar is an iron-nickel alloy, which shows practically no thermal expansion up to 150 °C. Crystalline α -quartz expands with a continuously increasing expansion coefficient. A solid-solid transition to β -quartz occurs at about 575 °C. On further heating, the sample then starts to shrink.

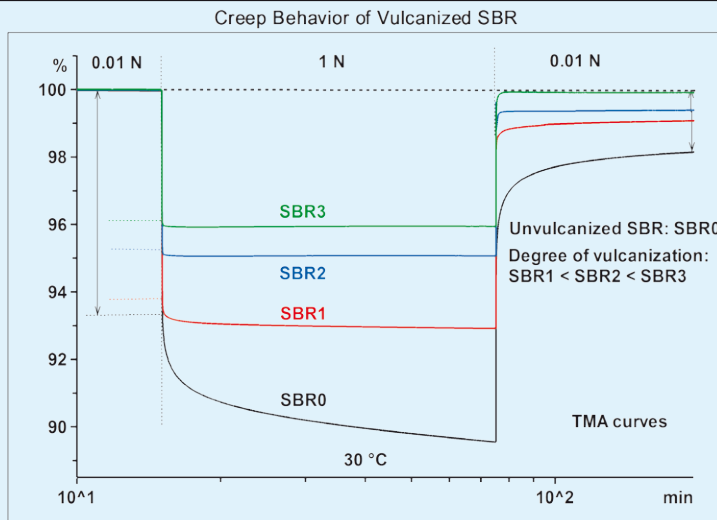
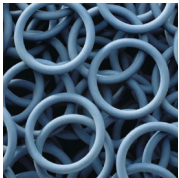

Creep behavior of elastomers

An important property of a seal is its creep and recovery behavior. Creep deformation consists of reversible viscoelastic relaxation and irreversible viscous flow components. In this application, several styrene-butadiene rubber (SBR) samples with different degrees of vulcanization were investigated. Unvulcanized SBR0 shows the largest elastic deformation (left arrow) and the largest irreversible deformation (right arrow). With increasing vulcanization, both the elastic deformation and the viscous flow decrease. Good sealing materials should not exhibit viscous flow.

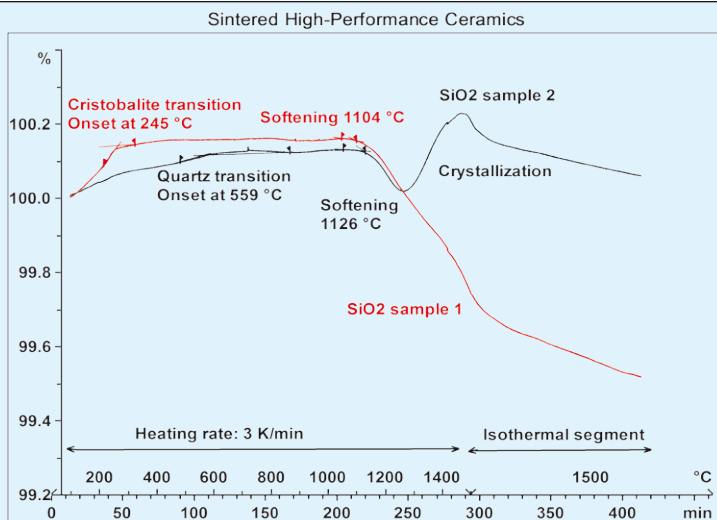

Sintered high-performance ceramics

High-performance ceramics exhibit high temperature stability. This is shown here with measurements of two sintered SiO_2 samples – a conventional SiO_2 sample 1 and a second type, sample 2. The cristobalite transition of sample 1 can be clearly seen at 245 °C. This occurs rapidly and often leads to cracks in the material. The second type of SiO_2 exhibits a slower quartz transition at a higher temperature, with less risk of crack formation. Sample 2 also contains crystallization nuclei; crystallization occurs from about 1200 °C onward. These properties make sample 2 a high-performance ceramic.

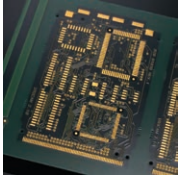

Characterization of PC Boards

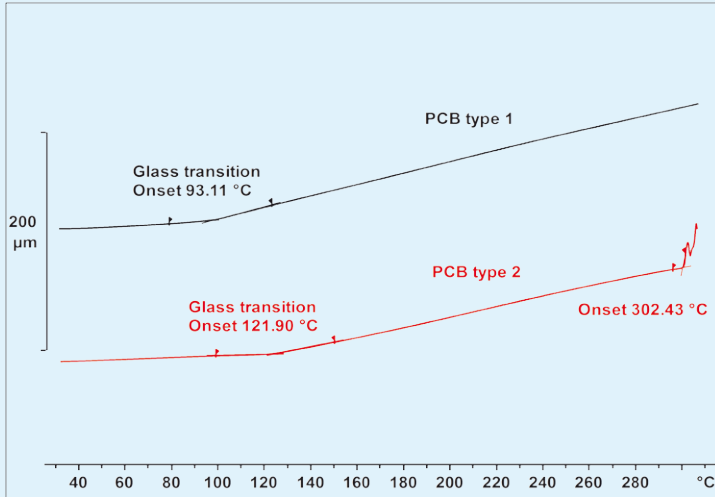

Delamination of composites

A printed circuit board (PCB) is a laminate consisting of several layers of glass fibers embedded in a thermosetting resin matrix. Important characteristics of PCBs are their glass transition temperature (T_g) and temperature stability. Both can be measured by TMA. The diagram shows TMA curves of two different PCBs. The changes in the slope of the curves at 93 and 122 °C correspond to the T_g of the PCBs. Decomposition of the resin matrix is accompanied by out-gassing. This forces the layers apart (delamination) and leads to spikes in the TMA curve. The curves show that PCB1 is more stable than PCB2.

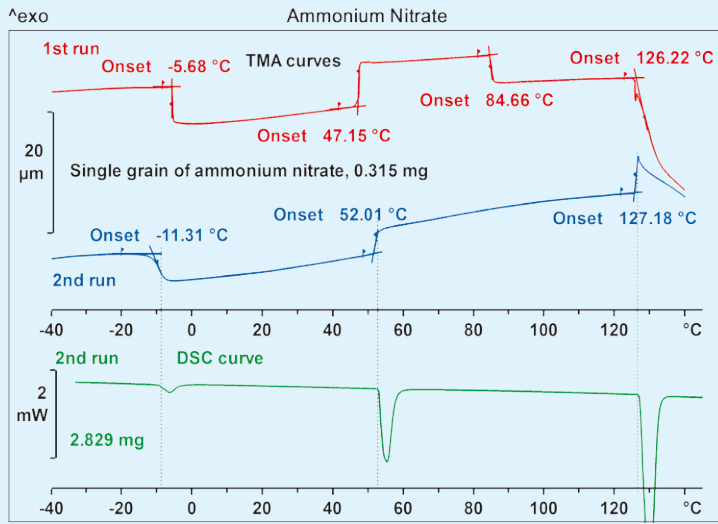

Solid-solid transitions by TMA and DSC

Solid-solid transitions are generally accompanied by volume changes. Transitions like this are observed as steps in the TMA curve. This is demonstrated using a single grain of ammonium nitrate, a substance used in many fertilizers and explosives. The curves show that the structural changes occur quite rapidly. The transition temperatures depend on internal stresses in the sample and hence on its thermal history. This explains the different shapes of the curves measured in the first and second heating run. The DSC curve (second heating run) is shown for comparison.

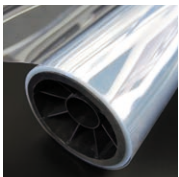

Film Samples by TMA

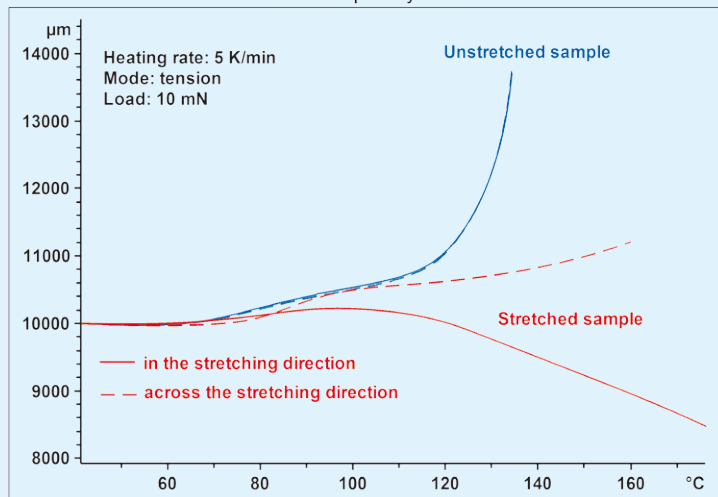

Shrinkage behavior of films

Stretched films often exhibit anisotropic mechanical properties. These can be investigated by measuring expansion or shrinkage behavior using TMA. The diagram shows the measurement curves of two different polyethersulfone films. The red curves were obtained from a stretched film in and across the direction of stretching. The blue curves are the results from an unstretched film, measured in two directions at right angles to each other. The unstretched sample clearly shows isotropic behavior whereas the stretched sample behaves very differently in the stretched and unstretched directions.



Gelation Time of an Adhesive

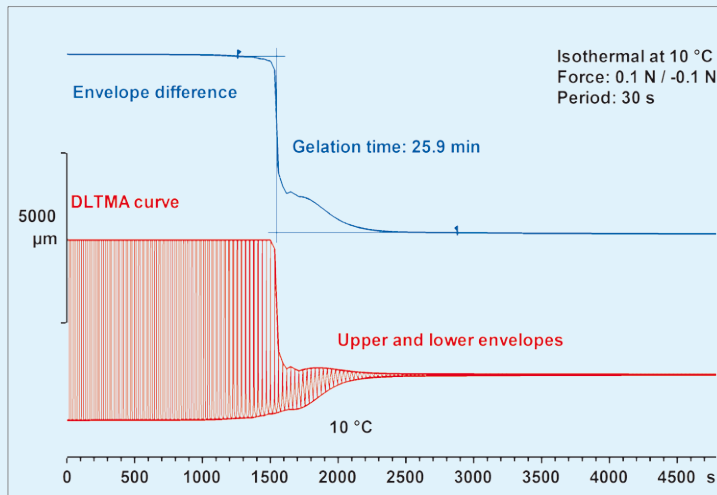

Gel formation by DLTMA

The gelation time (or pot life) is the time needed for the molecules in a thermosetting resin to form a gel. After gelation, the initially liquid resin can no longer be molded. Information about the gelation time is therefore of great practical importance regarding the workability of resins. The gelation time can be easily determined by DLTMA. While the sample is liquid, the probe switches between its highest and lowest position under the alternating load. After the gelation time, the probe sticks to the sample and the displacement amplitude rapidly decreases.



Swelling of Elastomers in Toluene

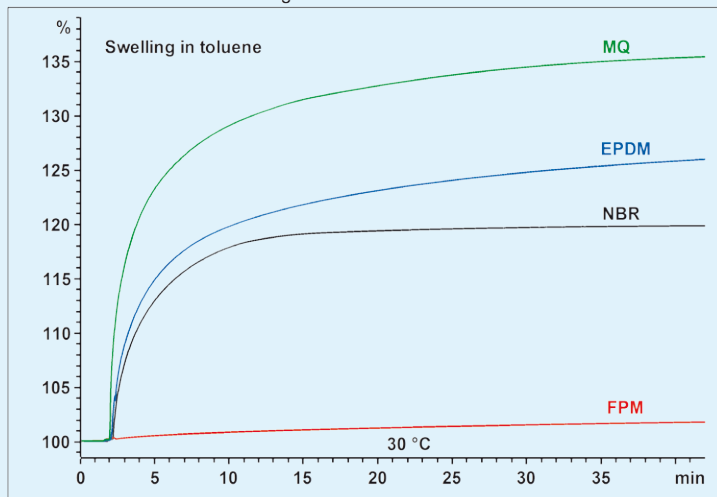

Swelling of elastomers

The swelling behavior of sealants in solvents is often important for their practical use. Swelling behavior can be measured using a TMA/SDTA 2+ equipped with a special swelling accessory. The diagram shows the swelling curves of four different elastomers in toluene at 30 $^{\circ}\text{C}$. A fluoro-elastomer (FPM) swells only about 2% in one direction. FPM is clearly resistant to toluene and can be used as a sealant when it is exposed to this solvent. The other three elastomers swell much more strongly, for example silicone rubber (MQ) swells by more than 35% in one direction in 35 minutes.



Curing of Epoxy Resin by DLTMA

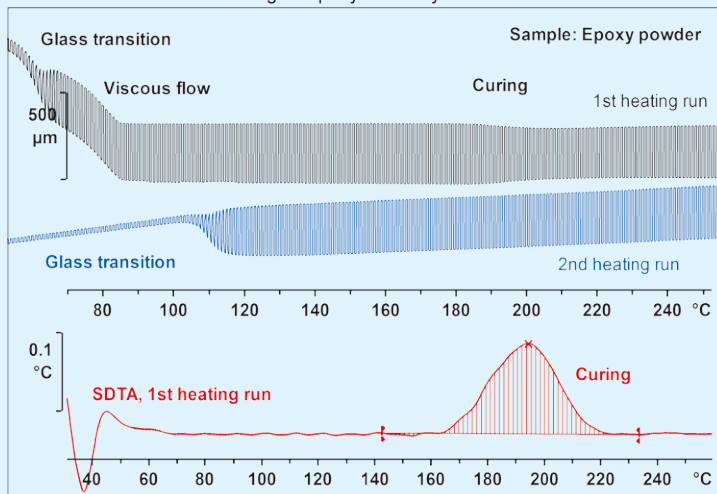

Curing of an epoxy resin by DLTMA

A precured epoxy resin was measured by DLTMA. In the glassy state, the resin is hard and the displacement amplitude with the alternating load used is small. The amplitude increases at the glass transition. After this, the resin becomes liquid and begins to flow; the amplitude remains constant but then decreases at about 190 $^{\circ}\text{C}$ due to curing of the resin. The curing process can also be seen as an exothermic peak in the simultaneously measured SDTA curve. In the second DLTMA heating run, the glass transition of the fully cured sample is observed at about 110 $^{\circ}\text{C}$.

TMA/SDTA 2+ Specifications

Temperature data	LF/1100	HT/1600	IC/600	LN/600
Temperature range	RT to 1100 °C	RT to 1600 °C	-80 to 600 °C	-150 to 600 °C
Temperature accuracy (RT to max. temperature)	±0.25 °C	±0.5 °C	±0.25 °C	±0.25 °C
Temperature accuracy (-70/-100 °C to RT)	n.a.		±0.35 °C	±0.35 °C
Temperature accuracy (-150 to -100 °C)	n.a.		n.a.	±0.5 °C
Temperature reproducibility	±0.15 °C	±0.35 °C	±0.25 °C	±0.25 °C
Heating (RT to max. temperature)	8 min	22 min	<6 min	<6 min
Heating (-70/-150 to 600 °C)	n.a.		<7 min	<6 min
Cooling (max. temperature to RT)	20 min	<40 min	13 min	<15 min
Cooling (RT to -70/-150 °C)	n.a.		22 min	15 min

Length data

Maximum sample length	20 mm			
Measurement range	±5 mm			
Resolution	0.5 nm			
Noise (RMS)	5 nm			
Reproducibility	±100 nm	±300/±500 nm (1100/1600 °C)	±100 nm	±50 nm

Force data

Force range	-0.1 to 1.0 N			
-------------	---------------	--	--	--

DLTMA data

Frequencies	0.01 to 1 Hz			
-------------	--------------	--	--	--

SDTA®-(Single differential Thermal Analysis)

SDTA® resolution	0.005 °C			
SDTA® noise (RMS)	0.01 °C	0.01 °C	0.02 °C	0.02 °C
SDTA® sensor type	R type		K type	
SDTA® signal time constant	33 s	33 s	38 s	38 s

Data sampling

Sampling rate	max. 10 data points per second			
---------------	--------------------------------	--	--	--

Approvals

IEC/EN61010-1, IEC/EN61010-2-010
 CAN/CSA-C22.2 No. 61010-1-04 & -2-010
 IEC61326-1 / EN61326-1 (class B)
 IEC61326-1 / EN61326-1 (Industrial requirements)
 FCC, Part 15, class A
 AS/NZS CISPR 11, AS/NZS 61000.4.3
 Conformity Mark: CE, CSA, C-Tick

www.mt.com/TMA

For more information

Mettler-Toledo GmbH, Analytical

CH-8603 Schwerzenbach, Switzerland
 Tel. +41 44 806 77 11
 Fax +41 44 806 72 60

Subject to technical changes
 © 02/2016 Mettler-Toledo GmbH, 30312613
 Marketing MatChar / MarCom Analytical



Quality certificate. Development, production and testing according to ISO 9001.



Environmental management system according to ISO 14001.



"European conformity". The CE conformity mark provides you with the assurance that our products comply with the EU directives.